

PULSE

MEGAMOUTH



USER'S MANUAL

FEATURES

1. This system is with cassette player and recorder.
2. Built-in 12V2.2A rechargeable battery. Suitable for both indoor and outdoor use.
3. Built-in one channel wireless receiver. With one handheld MIC, one body pack transmitter with headset MIC and lapel MIC.
4. With one 6.35mm MIC input jack and one RCA line input jack.
5. With one 6.35mm line out jack and one 3.5mm phone out jack.
6. With TONE and ECHO controls. Suitable for karaoke.
7. With power, charging, low battery and RF indicators.
8. Power supply : AC, DC 12V, built-in rechargeable battery.
9. Power Output: 30W(max)

CAUTION

1. Free from high temperature. Don't expose the device to hot equipment.
2. Don't place the device in the environment of humidity and dirt.
3. Place the device in the ventilated environment.
4. Don't pull the power cord while you pull out the plug. Hold the plug to pull out AC power.
5. Pull out the AC power if you will not use the device for a long period of time.
6. Your operation must be subjected to the specified voltage marked on the device and complied with this guide.
7. Don't open chassis: it is very dangerous to open the chassis or put your hand inside the chassis. If the device is not proper, pull out the plug at once and contact your retailer or the nearest distributor.

PARTS DESCRIPTION

Amplifier

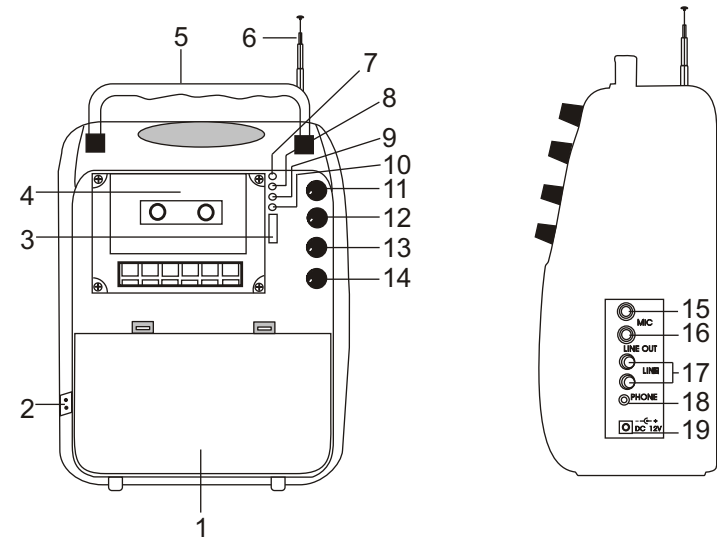

- | | |
|---------------------------------|--|
| 1. Battery compartment/cover | 11. Power switch and master volume control |
| 2. AC input jack | 12. Tape volume control |
| 3. AF level indicator | 13. Echo control |
| 4. Cassette player and recorder | 14. Tone control |
| 5. Handle | 15. MIC in jack |
| 6. Antenna | 16. Line out jack |
| 7. Low battery power indicator | 17. Line in jack |
| 8. Charging indicator | 18. Phone out jack |
| 9. Amplifier power indicator | 19. DC in jack |
| 10. Wireless MIC RF indicator | |

PARTS DESCRIPTION

Wireless Transmitter

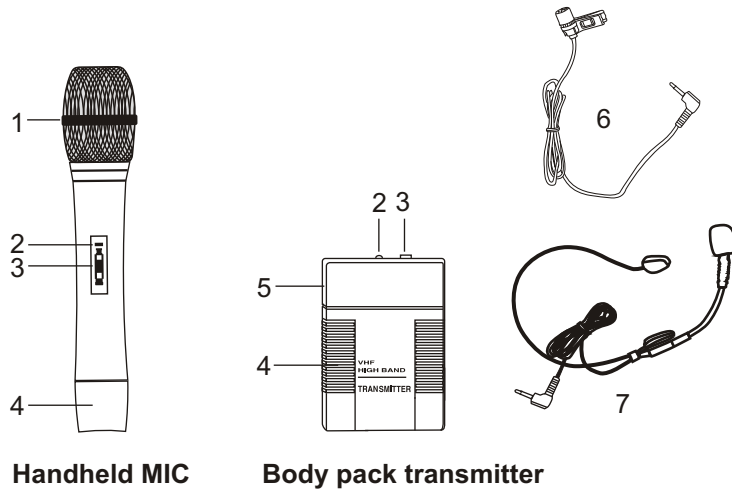

Handheld MIC

Body pack transmitter

1. Grille(capsule inside)
2. Power indicator
3. Power switch
4. Battery compartment
5. MIC in jack
6. Tie clip MIC
7. Headset MIC

OPERATION

1. Confirm the power:

A. When use AC power:

- 1) Please confirm the AC power is same as that marked on the device(Near AC in jack). Or the device may not work or be damaged.
- 2) Turn on the volume control in clockwise direction, power indicator will light to indicate normal power.

B. When use the built-in DC 12V rechargeable battery:

- 1) Open battery compartment. Connect rechargeable battery to DC connector with correct polarity(Red means +, Black means -).
- 2) Turn on the volume control in clockwise direction, power indicator will light to indicate normal power. If low battery indicator lights, it means battery power is low. Please connect AC power to charge the battery.

C. When use external DC power:

- 1) DC power can be input into by DC power jack directly.
- 2) When use car battery, voltage should be 12V-15V. Please note the correct polarity.

2. Recharging the battery:

- A. Plug the power cable into AC power jack for recharging. Charging time is about 10 hours.
- B. When CHARGE indicator turns to GREEN from RED, it means battery is fully charged.
- C. Please recharge the battery every 2 months if you don't use it for a long period of time.
- D. Battery will be charged either main power is off or on

3. Tape play:

Turn on the power/volume control in clockwise direction, power indicator will light red. Press the STOP/EJECT key on the cassette. Cassette door will open. Insert tape and close the cassette by pushing the top right corner of cassette door. Press PLAY/PAUSE button to start playing of tape. The signal level indicator shows the signal strength. Use power/volume control

OPERATION

And TAPE volume control to adjust the volume. Adjust tone control to achieve the best sound quality.

4. Tape record:

Open the cassette door and insert a blank tape. Press the REC key and PLAY key simultaneously to start recording. Signal from wireless microphone, MIC in jack and Line in jack can be recorded.

5. Wireless Microphone:

A. Insert a 9V battery into the wireless transmitter. Turn on transmitter power switch, power LED indicator will flash Once then off.

NOTE: When transmitter power indicator lights red, it means the transmitter battery power is low. Please replace with new battery.

B. RF indicator on amplifier will light.

C. Extend the antenna on the top of amplifier fully.

D. Adjust amplifier volume, tone, echo control to a suitable level.

E. Keep transmitter at least 1m from speaker of main unit to avoid feedback. If feedback happens, lower the volume and move transmitter away from main unit.

6. Wired Microphone:

Plug wired microphone into MIC input jack. Keep MIC head away from the speaker of main unit to avoid feedback.

7. External audio source:

You can play other audio device by connecting output of other audio source to line input jack.

8. Line out:

Connect line out to external amplifier to amplify the sound.

9. Phone out: Connect phone out to earphone.

SPECIFICATIONS

AMPLIFIER

Receiving Mode:	VHF
Output Impedance:	600 Ω
Frequency Range:	173~175MHz
S/N Ratio:	\geq 60dB
Stability for frequency:	+/-0.005%(-20°C ~40°C)
Power Output:	30W(MAX)
Effective Distance:	50M (open field)
Power supply:	AC 230V 50Hz;DC 12V-15V

TRANSMITTER

Frequency range:	VHF 173~175MHz
Dynamic range:	80dB
Frequency Response:	100-10KHz
Working Temperature:	-20°C~40°C
Battery Voltage:	9V battery
Battery Life:	about 10 hours