

Technical Specifications

Power	AC 120V 60Hz	AC 230-250V 50/60Hz
Fuse	20mm Glass T6.3A Fast Blow	20mm Glass T5A Fast Blow
Lamps	1 x 24V 250W Part No. ELC 24V 250W	
Dimension	500mm x 200mm x 155mm / 19.69in x 7.87in x 6.1in	
Weight	10 kg / 22 lbs	

=====

=For further requirements, contact the nearest authorized technical assistance office

=====

=

Intelligent Scanner

Professional Lighting Technology

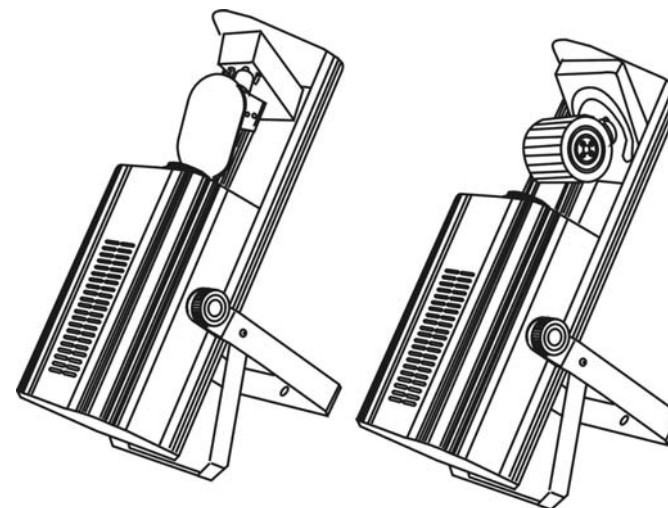

User Guide

Please read these instructions carefully before use

Built for the best performance !

E. FIXTURE CLEANING

The cleaning of internal and external optical lenses and/or mirrors must be carried out periodically to optimize light output. Cleaning frequency depends on the environment in which the fixture operates: damp, smoky or particularly dirty surroundings can cause greater accumulation of dirt on the unit's optics.

- Clean with a soft cloth using normal glass cleaning products.
- Always dry the parts carefully.
- Clean the external optics at least once every 20 days. Clean the internal optics at least every 30/60 days.

EC Declaration of Conformity

We declare that our products (lighting equipments) comply with the following specification and bears CE mark in accordance with the provision of the Electromagnetic Compatibility (EMC) Directive 89/336/EEC.

EN55014-2: 1997 A1:2001, EN61000-4-2: 1995; EN61000-4-3:2002;
EN61000-4-4: 1995; EN61000-4-5: 1995, EN61000-4-6:1996,
EN61000-4-11: 1994.

&

Harmonized Standard

EN60598-1: 2000+ALL:2000+A12:2002
Safety of household and similar electrical appliances
Part 1 : General requirements

INDEX

A. GENERAL INSTRUCTIONS

B. MAIN FEATURES

C. LAMP

D. HOW TO CONTROL THE UNIT

- (1) By universal DMX controller
- (2) Preprogrammed function
- (3) By easy controller

E. FIXTURE CLEANING

(2) Preprogram functions

The unit can be linked together as master/slave in daisy chain in linkage as many units as required and run by built in preprogrammed chase sequences automatically or by sound activation.

When linking the Barrel and the Scanner in stand alone mode, the Barrel must be used as the master head.

Not need to set the dipswitches in master/slave mode.

* 2-light show

Dipswitch 10 "off" means the unit works normally and "on" means inversion. In order to creating a great light show, you can set dip switch 10 "on" on any unit that is linking to the master unit to get contrast movement to each other, even if you have two units only. Dipswitch 10 on the first unit is no use in the DMX linking, as it is the master unit that operates the light show.

3C (3) By easy controller

The easy remote control is used only in master/slave mode. By connecting to the 1/4" microphone jack of the first unit, you will find that the remote control on the first unit will control all the other units for Stand by, Strobe/Next and Fast/Slow function.

1. **STAND BY** : To blackout all the unit.
2. **STROBE/NEXT** : Under FAST mode, the light will strobe in three different ways:
 - a.) Strobe in different gobos and colors.
 - b.) Synchronous strobe in white color.
 - c.) Two-light strobe in white color.

If the unit in slow mode, press NEXT button to choose desired color and gobo. It will change twelve colors and then change one gobo.

3. **FAST/SLOW** : When the LED is off, it is in FAST mode. The unit's movement-Pan/Tilt & Gobo/Color is sound activated. If the LED on, it is in SLOW mode, Pan/Tilt is sound activated but Gobo/Color wheel are static, controlled by Next button.

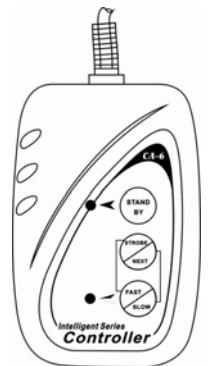

DMX512 CONFIGURATION						
CHANNEL 1	CHANNEL 2	CHANNEL 3	CHANNEL 4		CHANNEL 5	
SHUTTER	GOBO	COLOR	PAN		TILT	
			FLAT	BARREL	FLAT	BARREL
255 ⚡⚡⚡⚡ ⚡⚡ ⚡ Gobo Shaking 196 ⚡⚡⚡⚡ ⚡⚡ ⚡ 136 Gobo+Color ⚡⚡⚡⚡ ⚡⚡⚡ ⚡ Color 92 ⚡⚡⚡⚡ ⚡⚡ ⚡ 16 Gobo Stopped 0	255 Fast ⤿ ⤿ ⤿ Slow ⤿ ⤿ 128 Gobo 14 120 Gobo 13 112 Gobo 12 104 Gobo 11 96 Gobo 10 88 Gobo 9 80 Gobo 8 72 Gobo 7 64 Gobo 6 56 Gobo 5 48 Gobo 4 40 Gobo 3 32 Gobo 2 24 Gobo 1 16 Open 0 Blackout	255 Fast ⤿ ⤿ ⤿ Slow ⤿ ⤿ 128 Magenta 121 Yellow 110 Blue 99 Light green 88 Pink 77 Purple 66 Red 55 Amber 44 Light blue 33 Orange 22 Green 11 White 0				
GOBOS						

4C

A. GENERAL INSTRUCTIONS

Please read the enclosed instructions carefully as they include important points about safety for the installation, usage and maintenance of the unit.

- Start the address

How to address your DMX512 system:

1. Select the channels of DMX controller
2. Dipswitches

Dip	#1	#2	#3	#4	#5	#6	#7	#8	#9
Value	1	2	4	8	16	32	64	128	256

- Examples:

Channel 01 : dip / on : #1 (=1)
 Channel 06 : dip / on : #2, #3 (2+4=6)
 Channel 11 : dip / on : #1, #2,#4 (1+2+8=11)
 Channel 16 : dip / on : #5 (=16)

- Please keep this booklet with the unit for future consultation. If you sell the unit to another user, be sure that the new user also receives this instruction booklet thus giving them the necessary information about the use and general warnings regarding the unit.
- Before the initial start-up, please unpack and carefully check all components in case any damage may have occurred during shipping.
- Locate a suitable spot for your device where there is good ventilation. Also, make sure that no ventilating fans or slots are blocked.
- Protect our environment! Please dispose of the packing boxes properly.
- The electrical work that is necessary for installation must done by qualified personnel.
- Always remember to unplug the unit from the main power before any service is done. Do not open the unit. There are no serviceable parts inside.
- It is very important to ground the yellow/green conductor to earth in order to meet regulations for safety.
- Check the surrounding area and make sure there are no flammable liquids, water or metal objects that could enter the fixture. If a foreign object enters the unit, immediately disconnect the main power. Also, place the fixture in a well-ventilated room at about 15 cm from the walls.
- Do not touch any wires during operation, as high voltage is hazardous.
- In the event of serious operating problems, stop using the unit immediately. Never try to repair the unit yourself. Repairs carried out by unqualified personnel can lead to damage or malfunction. Please contact the nearest authorized Technical Assistance Center. Always use genuine spare parts.

B. MAIN FEATURES

- Voltage : AC 120V 60Hz or 230-250V 50/60Hz
- Bulb : ELC 24V 250W
- The unit is a DMX512 scanner. It features full DMX512 control, 14 gobos plus open and 11 colors plus white, accurate focusable optics system and stepper motor with blackout feature. Fan cooled.
- It can be operated by DMX512 control or can be used as an individual unit without a control.
- It can be linked together in master/slave combination units, as many as required in 4 channels and run by built-in preprogrammed chase sequences automatically or by sound activation through an internal microphone to create an intelligent effect.
- Please use a 3 pin XLR cable/plug when connecting them together.
- It features different preprogrammed chase patterns.
- Dimensions : 500mm x 200mm x 155 mm / 19.69 in x 7.87 in x 6.1 in
- Weight : 10 kg / 22 lbs

C. LAMP

ELC 24V 250W

- Always switch off the mains supply and never handle the lamp or luminaire when it is hot.
- Do not touch the bulb with bare hands. If this does happen, clean the lamp with denatured alcohol and wipe with a lint free cloth before installing.

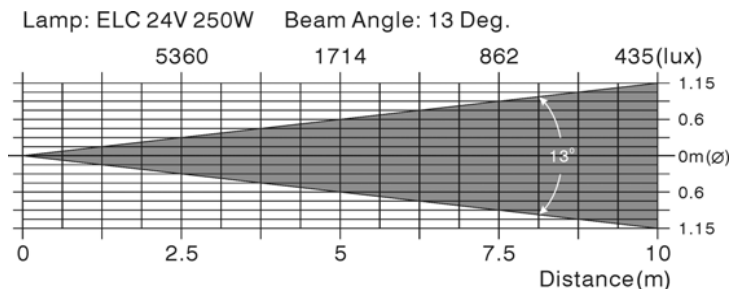

D. HOW TO CONTROL THE UNIT

(1) By universal DMX controller

The DMX512 is widely used in intelligent lighting control, with a maximum of 512 channels.

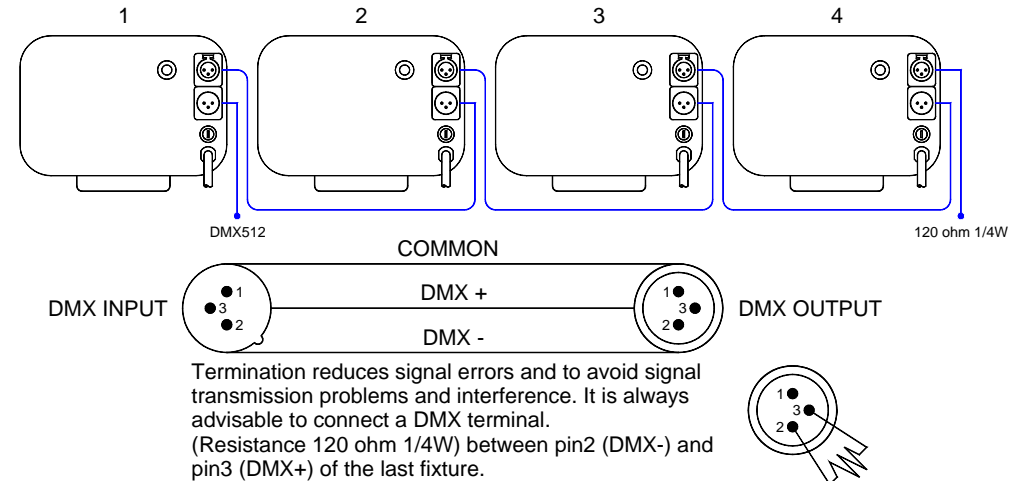

5C

- A DMX512 system requires a controller, lighting equipment and cable. These are connected together in a “daisy chain” with the terminator at the end. The cable cannot be branched or split to a “Y” cable.
- The terminator requires a 90-120 Ohm 1/4 Watt resistor soldered between two signal cables.
- The DMX512 uses a very high-speed signal. Inadequate or damaged cables, bad solder joints or corroded connectors can easily distort the signal and shut down the system. A reliable DMX512 system starts with good quality cables.
- Each lighting unit needs to have an address set to receive the data sent by the controller. The address number is between 0-511. The end of the DMX512 system should be terminated reducing signal errors.
- 3 pin XLR connectors are more popular than 5 pin XLR.
3 pin XLR: Pin 1: GND, Pin 2: Negative signal (-), Pin 3: Positive signal (+)
5 pin XLR: Pin 1: GND, Pin 2: Negative signal (-), Pin 3: Positive signal (+)